

Zbarvení a označení
Camouflage and markings

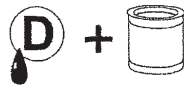

Ford WOT 3, RAF, 1943

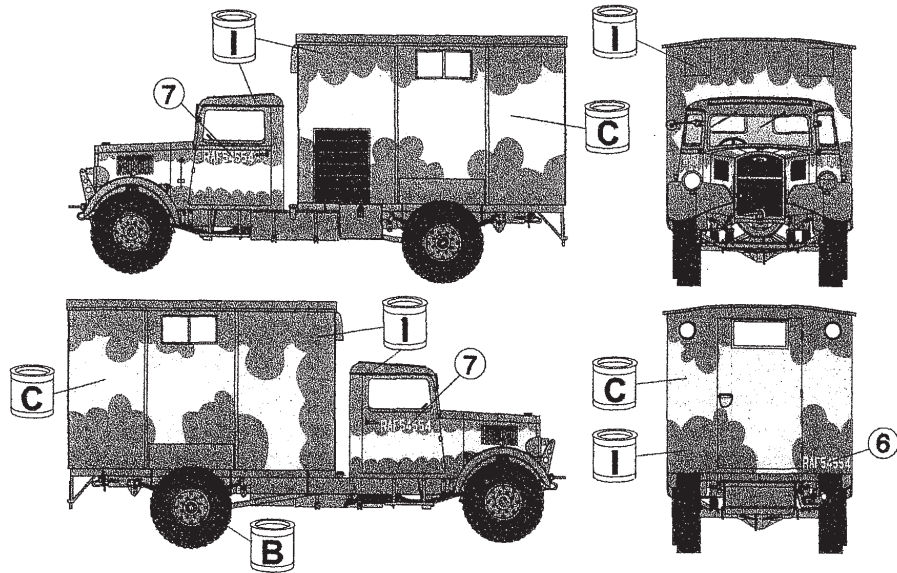

Ford WOT 3, RAF Duxford, 1942

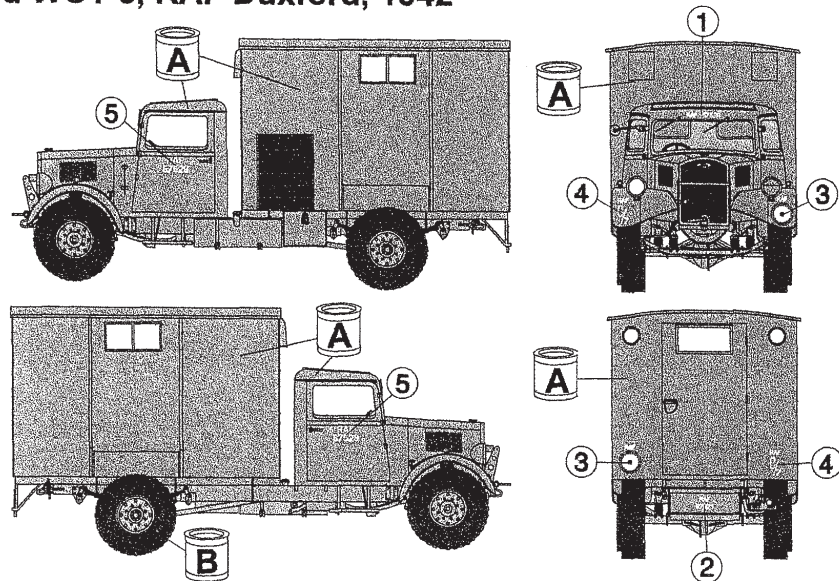

Camouflage and markings - reconstruction

199

plusmodel

Scale
1/35

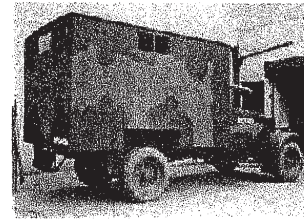

FORD
WOT 3
RAF

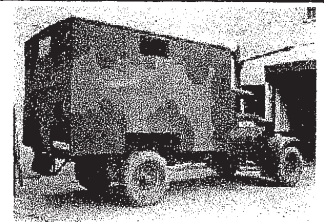

Ford WOT 3

Jedenapůltunový nákladní automobil 4x2 WOT Ford (Fordson) 3 byl vyráběn v letech 1939-44 v počtu téměř 18000 kusů ve Velké Británii pro armádu a RAF.

Na voze byly užívány různé nástavby jako dílny, dodávka, valník, existovala i verze s otevřenou kabinou pro Indii.

Technické parametry:

Jedenapůltunový nákladní automobil 4x2
Motor – čtyřdobý vidlicový osmiválec Ford
Výkon – 63kW(85bhp)
Obsah – 3621 cm²
Převodovka – čtyřrychlostní, zpátečka
Brzdy – mechanické na všech kolech
Rozvor – 3645 mm
Délka – 5766
Šířka 2184 mm
Výška – 2718 mm
Hmotnost – 2946 kg

Ford WOT 3

Production of the 1,5 ton 4x2 military vehicle WOT Ford (Fordson) 3 was during 1939 to 1944 in Great Britain for Army and RAF. There were built about 18 000 vehicles.

It was produced with various types of machinery bodies, as delivery truck, flat bed, workshop-lorry and open cab version for India

Specifications:

1,5 ton 4x2 military vehicle
Engine - V eight cylinder, four-stroke, 63kW(85bhp)
Engine dimension - 3, 621 L
Engine power - 63kW(85bhp)
Gearbox - Four forward, one reverse
Brakes - mechanical on all wheels
Wheel base- 3645 mm
Length - 5766 mm
Width - 2184 mm
Height - 2718 mm
Weight - 2946 kg

Při stavbě postupujte podle instruktážního obrázku

Follow the instruction drawing the assembly.

Upozornění: Během opracování může vznikat prach, který může dráždit dýchací cesty. Použijte ochranu očí při odšťihování kovových dílů.

Notice: Machining can produce dust which can be irritating to the respiratory tract. Metal parts should be cut off using protection eyesight.

MODELCHOICE.NET
ORDER & BUY DIRECTLY FROM MANUFACTURERS

Plus Model s.r.o.
Jižní 56, 370 10 České Budějovice
Czech Republic
<http://www.plusmodel.cz>
e-mail: plusmodel@plusmodel.cz

MODELCHOICE.NET
ORDER & BUY DIRECTLY FROM MANUFACTURERS

www.plusmodel.cz

Resinové díly - Resin parts

Odříznout
Remove

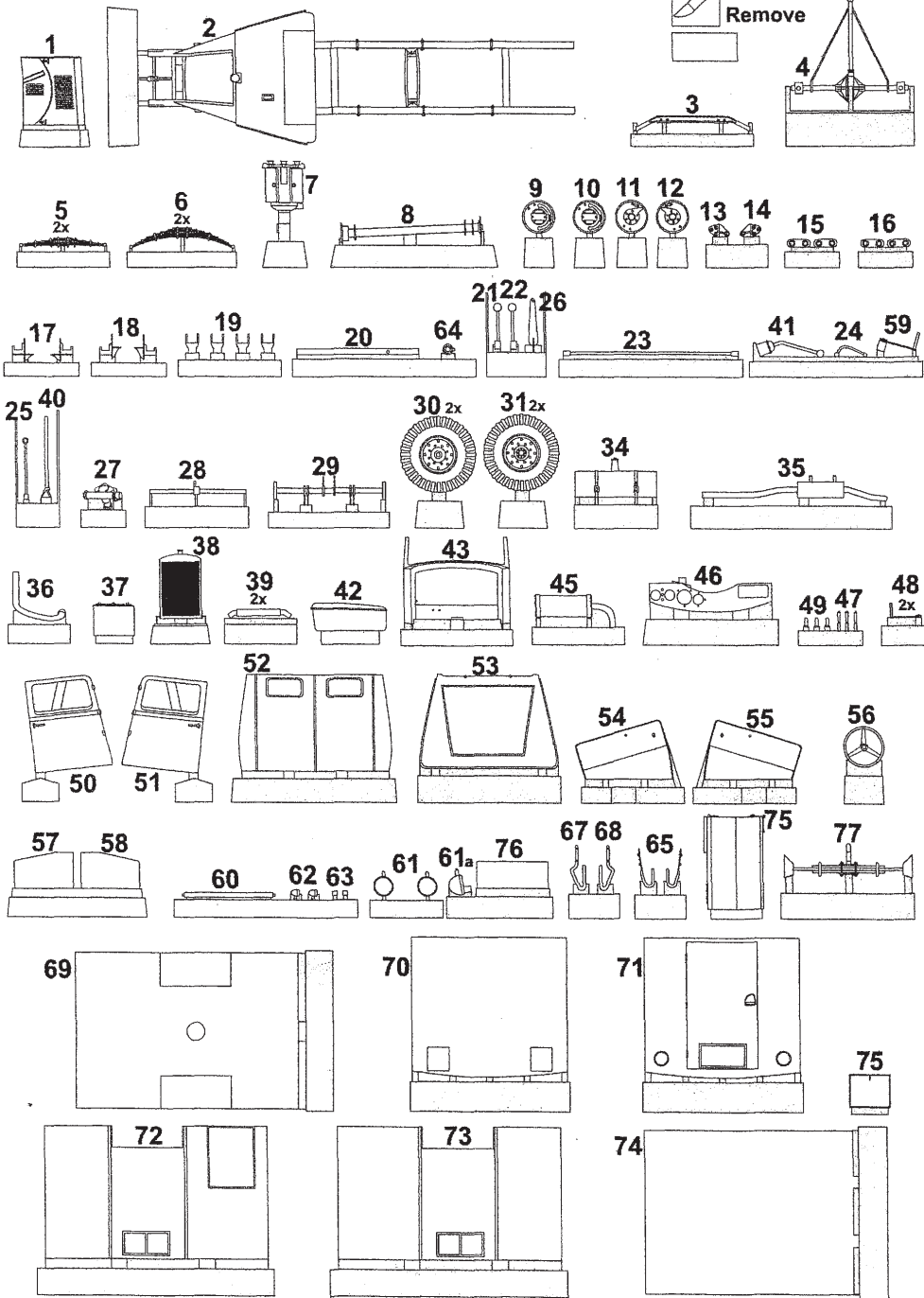

21

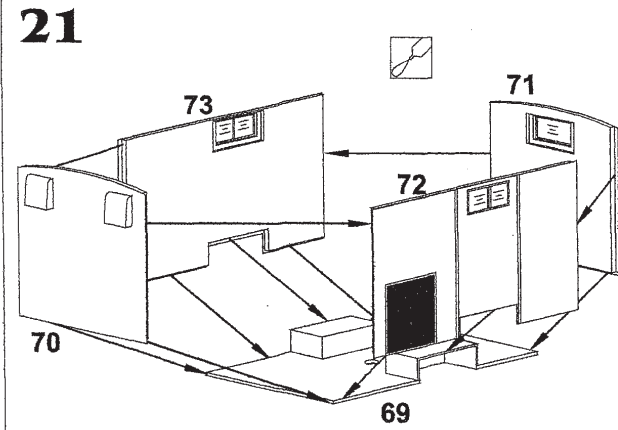

22

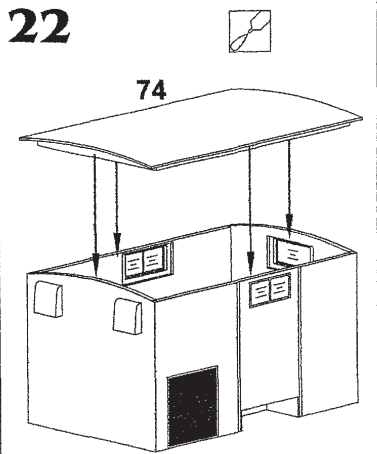

23

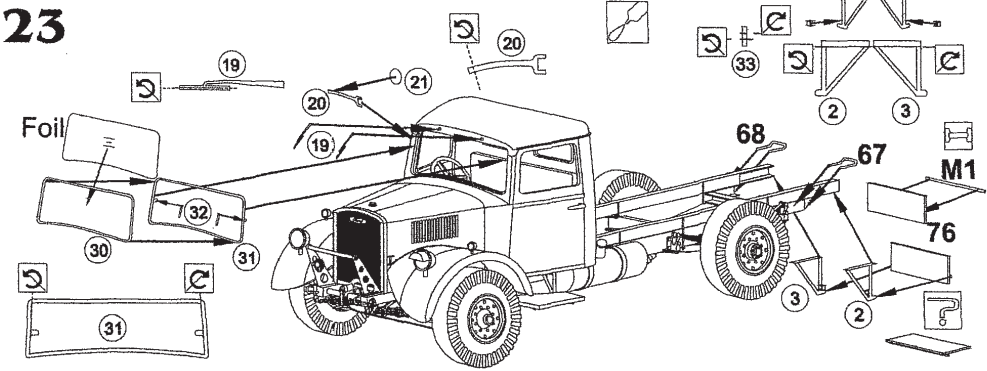

24

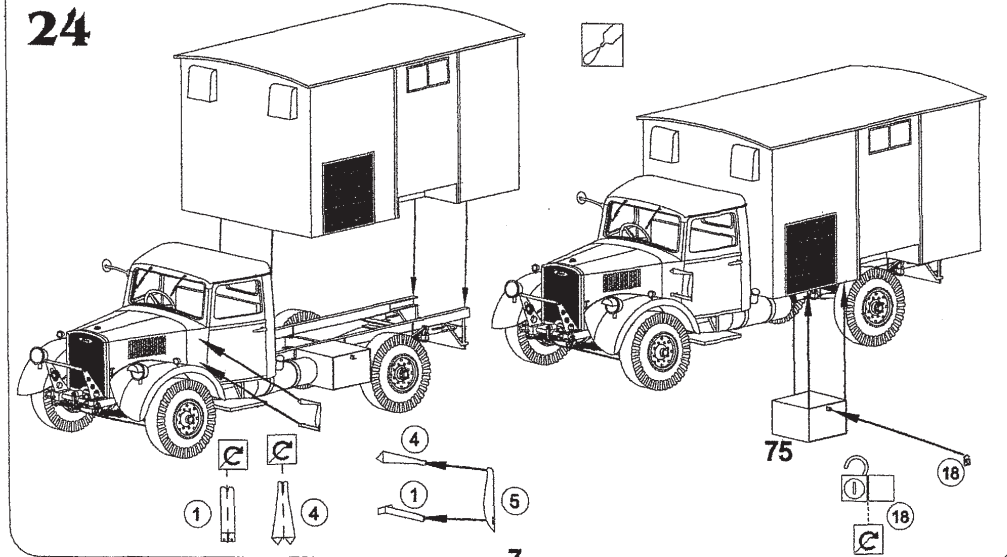

18

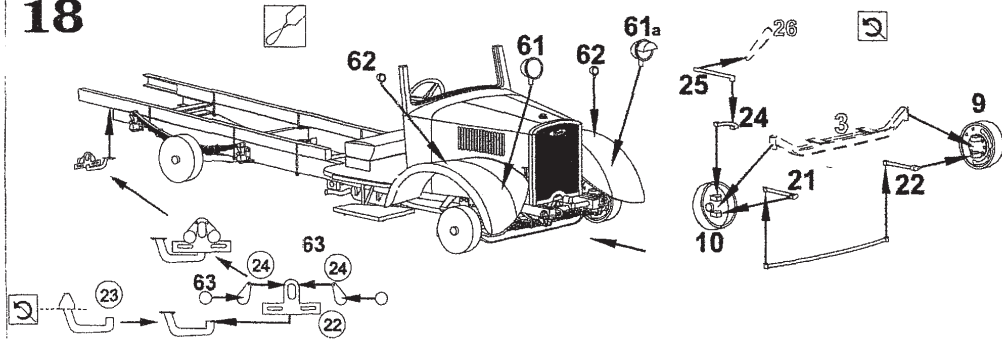

19

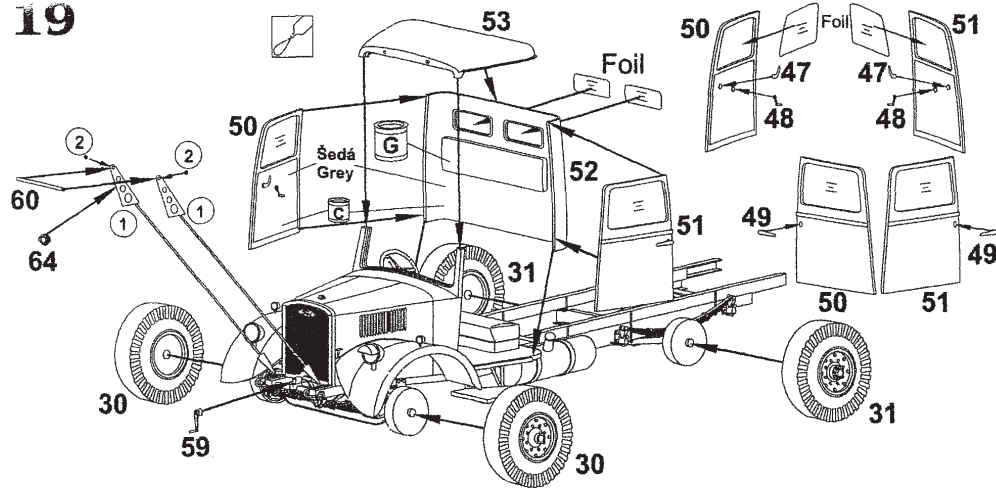

20

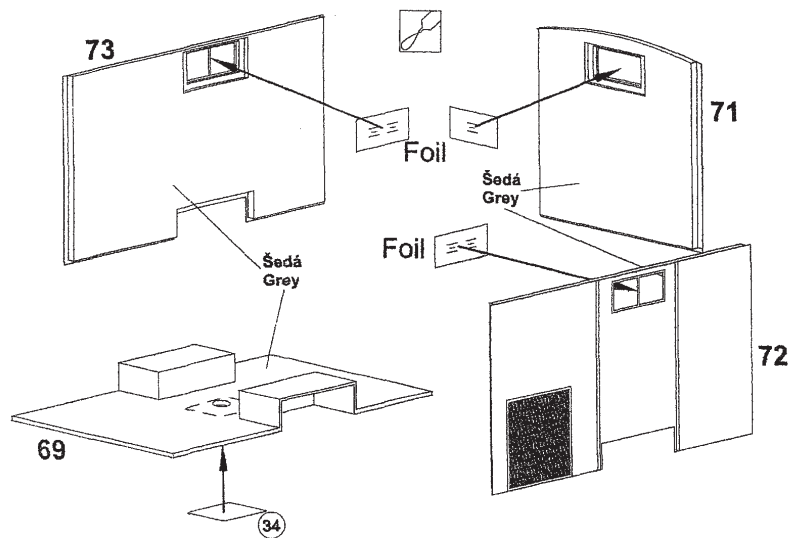

Foil

Obtisky - Decals

Kovové díly - Metal parts

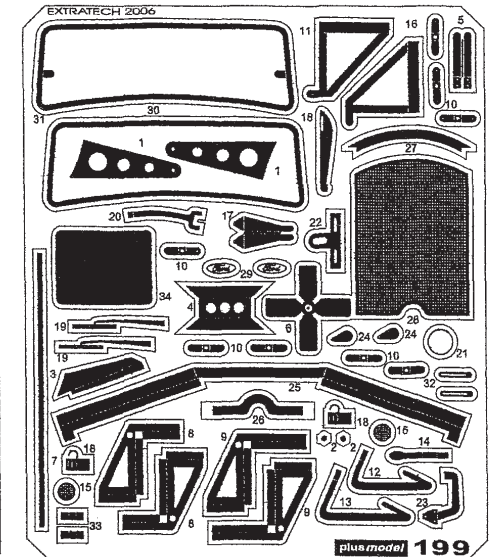
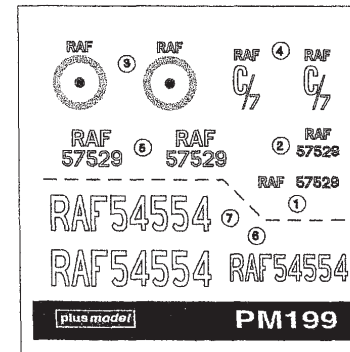

M1

Symboly - Symbols

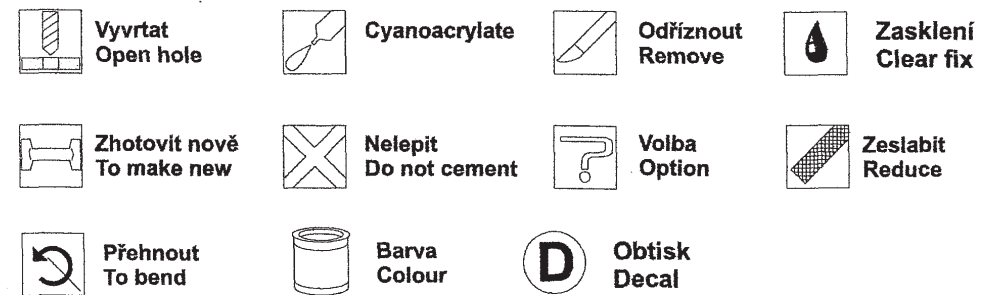

Barvy - Colours



Stavební postup - Assembly instructions

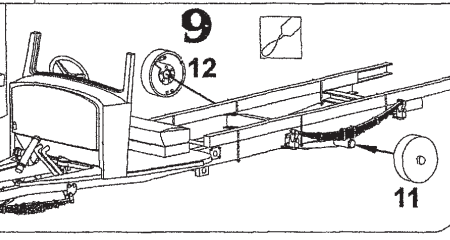
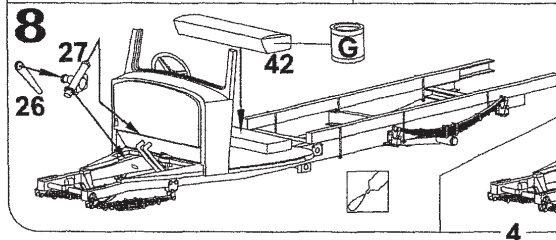
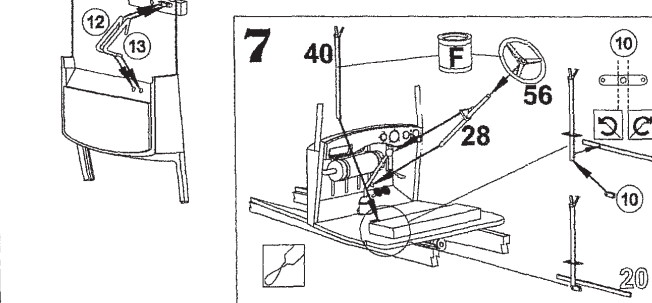
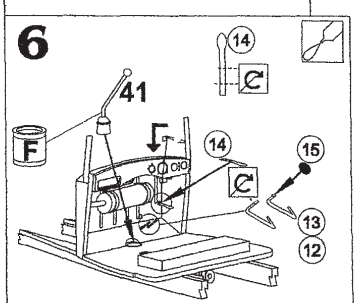
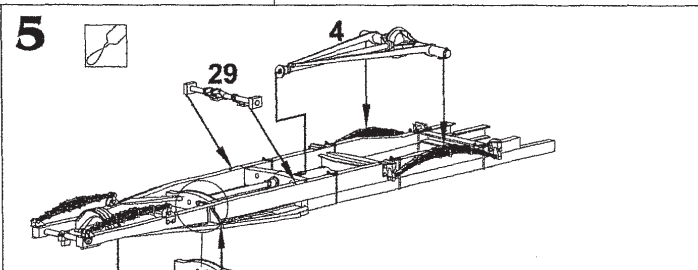
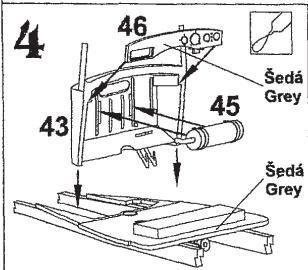
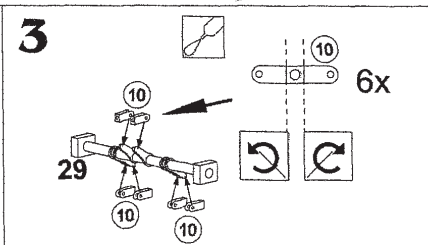
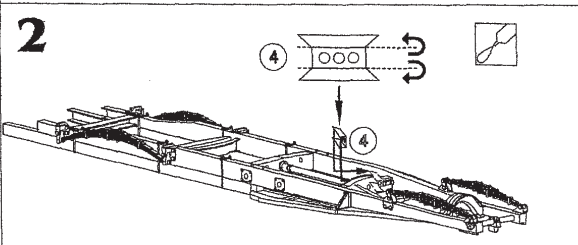
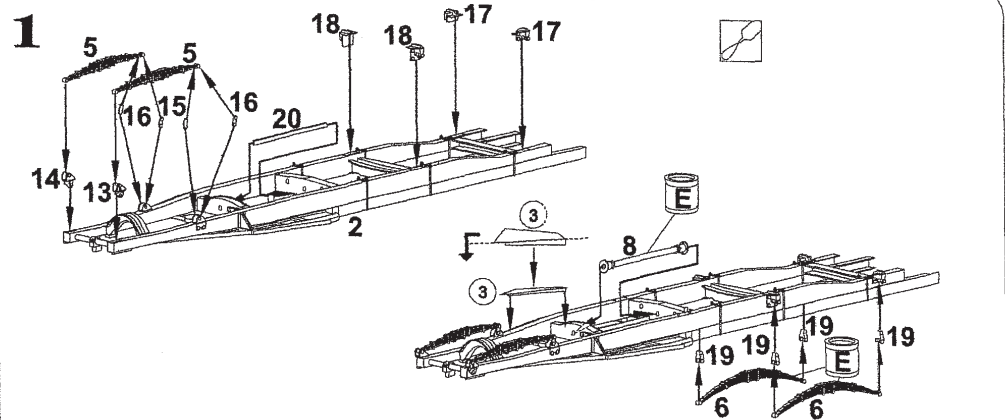

Stavební postup - Assembly instructions

